

**AIR-HANDLING UNITS
DUPLXBASE PT
500, 900, 1800, 2800, 3500
(RD6)
Installation manual**



Contents

1	Important notices	3
2	Safety instructions	4
2.1	General safety	4
2.2	Operational safety	4
3	Storage and transport	4
4	Description	6
4.1	General	6
4.2	Intended use	6
5	Installation	6
5.1	Safety instructions	6
5.2	Hygienic instructions and requirements	7
5.3	Configuring orientation of the unit	7
5.3.1	RD6 (aMotion) control system	7
5.3.2	RD5 control system	9
5.4	Installation	9
5.5	Ductwork connections	10
5.6	Connecting the condensate drain pipe	11
5.7	Installing air filters	12
5.8	Installing and connecting filter manometers	12
5.9	Installing hot water heating coil	14
5.10	Installing mixing valve of hot water air heater	15
5.11	Installing shut-off dampers e1, i1	15
5.12	Installing flexible flanges	15
5.13	Installing and connecting water chiller to the cool source	15
5.14	Installing mixing valve of the water chiller	15
5.15	Installing direct chiller	15
5.16	Installing electric heater / pre-heater	15
5.17	Installing manometers to control constant flow and constant pressure	15
6	Electrical connection	16
7	Unit commissioning	16
7.1	Safety instructions	16
7.2	Hygienic instructions for compliance with VDI 6022	17
7.2.1	General instructions	17
7.2.2	Required qualifications of personnel as per the type of activity	18
7.3	Protection of idle unit	18
8	Unit control	19
8.1	Control system RD6 (aMotion)	19
8.1.1	Connection via ethernet interface	19
8.1.2	RD6 (aMotion) cloud	20
8.1.3	Mobile application	20
8.2	Control system RD5	21
9	Package disposal	21
10	Repairs, spare parts	21
11	Warranty	21

Items or sections marked with ↻ (or with a grey background) apply only to ventilation units manufactured in compliance with the hygienic requirements of Regulation VDI 6022 (indicated on the production label, see following chapters).

1 Important notices

- Electrical connections, commissioning and adjustment of the appliance may only be carried out by qualified electrical engineers.
- Before the installation and commissioning of the appliance carefully read the installation, use and maintenance manual, the controller operation manual and, where applicable, the service documentation.
- The appliance and all its accessories must be installed and used in compliance with the design, technical conditions specified by the manufacturer and applicable legislation and technical standards in effect.
- The appliance may not be installed and operated in an aggressive environment that could damage its external and internal mechanical parts.
- Before putting the appliance into permanent operation an initial inspection report on the appliance's power supply must be provided.
- ↻ Before putting the appliance into operation an approval test (see VDI 2079 and DIN EN V 12599) of the entire HVAC system of which the appliance forms part must be conducted. The test must include the examination of hygienic requirements as per VDI 6022 and must be documented. The user must be able to present the approval test report at any time. If the above requirements are not met, the manufacturer cannot ensure compliance with hygienic requirements.

The manufacturer is not liable for any damage caused by

- unprofessional installation and operation that is not in compliance with the operation and maintenance manual and general practices applied during installation and operation of HVAC equipment and control systems.
- using the equipment to other purposes than stated in the Chapter 4.2 Intended use.

2 Safety instructions

2.1 General safety

1. Only adults sufficiently familiar with the operation and maintenance manual may operate the equipment.
2. The user must not tamper with or modify any part of the equipment, particularly the power supply lines!
3. Only professional service technicians with relevant qualifications may perform equipment repairs. Unprofessional repairs are very risky and may result in loss of warranty.
4. Before opening the equipment's door for cleaning, filter replacement or general maintenance always make sure that the equipment is disconnected from power supply and prevent its reconnection by another person.
5. For rules of connecting air duct please see chapter 5.5.
6. If the equipment has been out of operation for a prolonged period of time, extra care should be taken when putting it back into operation.

2.2 Operational safety

1. Air handling units DUPLEXbase with heat recovery are designed for comfort ventilation of premises with basic environment. If the appliance is used for other purposes (e.g. drying out of new buildings, extraction of dust or building materials) the manufacturer bears no responsibility for the damage caused.
2. The indoor version of the unit is intended for a basic environment - ambient temperatures must be between +5 and + 55 °C with relative humidity up to 60 % (60 % relative humidity up to 20°C). If the appliance is located elsewhere, its sufficient protection must be ensured. The appliance can only be operated in an environment where there is no risk of fire or an explosion of flammable gases and fumes
3. The appliance must be operated within the temperature range of ventilation air between -35°C and +40 °C with relative exhaust air humidity up to 80%. The transported air must not contain
 - explosive and flammable gases and fumes
 - organic solvents or aggressive substances that might damage mechanical parts of the unit. If there is a danger of such gases and fumes temporarily entering the duct system (e.g. during floor bonding, painting), the unit must be switched off sufficiently in advance.
4. The appliance is designed for environments with Class ETA 1 extract air; in environments with extract air Class ETA 2 and ETA 3 it is necessary to comply with conditions specified in the chapter 5.2.
5. In case the air is extracted directly from the toilet bowl the use of chlorine-based cleaners can cause oxidation of metal parts of the unit, making its lifetime shorter.
6. If water heater is installed in the unit follow the steps in the Chapter 5.9.
7. If water cooler is installed in the unit follow the steps in the Chapter 5.13.
8. In the event of a failure the appliance must be disconnected from power supply as soon as possible!

3 Storage and transport

1. Store the appliance in such a way that the device or its packaging does not get damaged. Until its commissioning, the appliance may only be stored only in dry, covered places so that
 - the appliance or its parts remain protected from rough weather, direct sunshine and ultraviolet radiation;
 - the appliance or its parts are exposed to ambient temperatures ranging from -25°C to +55°C;
 - surfaces that will come in contact with transported air and all electrical components remain dry and clean.
2. Do not expose the heat recovery core to ultraviolet radiation; store it in a dark place.
3. Protect the unit from ingress of impurities. Packaging may only be removed immediately before the installation of the appliance in its operating position. If that is not the case, all parts must be checked for cleanliness before installation and thoroughly cleaned if necessary.
4. The appliance must not contain any operational liquids (e.g. water in the hot water heater, water chiller etc.) during storage and transport.

5. The appliance may only be transported on handling blocks (included). During transportation the appliance must be protected against mechanical damage and water penetration and all openings must be covered with protective covers.
6. During transportation the appliance must be secured against falling. The mode of transport must also eliminate any falls of the appliance or instances of the appliance getting loose.
7. Activities near the unit such as grinding, cutting and other ancillary works that could irretrievably damage the surface or individual parts of the unit are prohibited.

- ! When handling or transporting the unit, ensure that it is securely positioned. Secure the unit and its accessories against falling or tipping over.

Solely permitted methods of handling

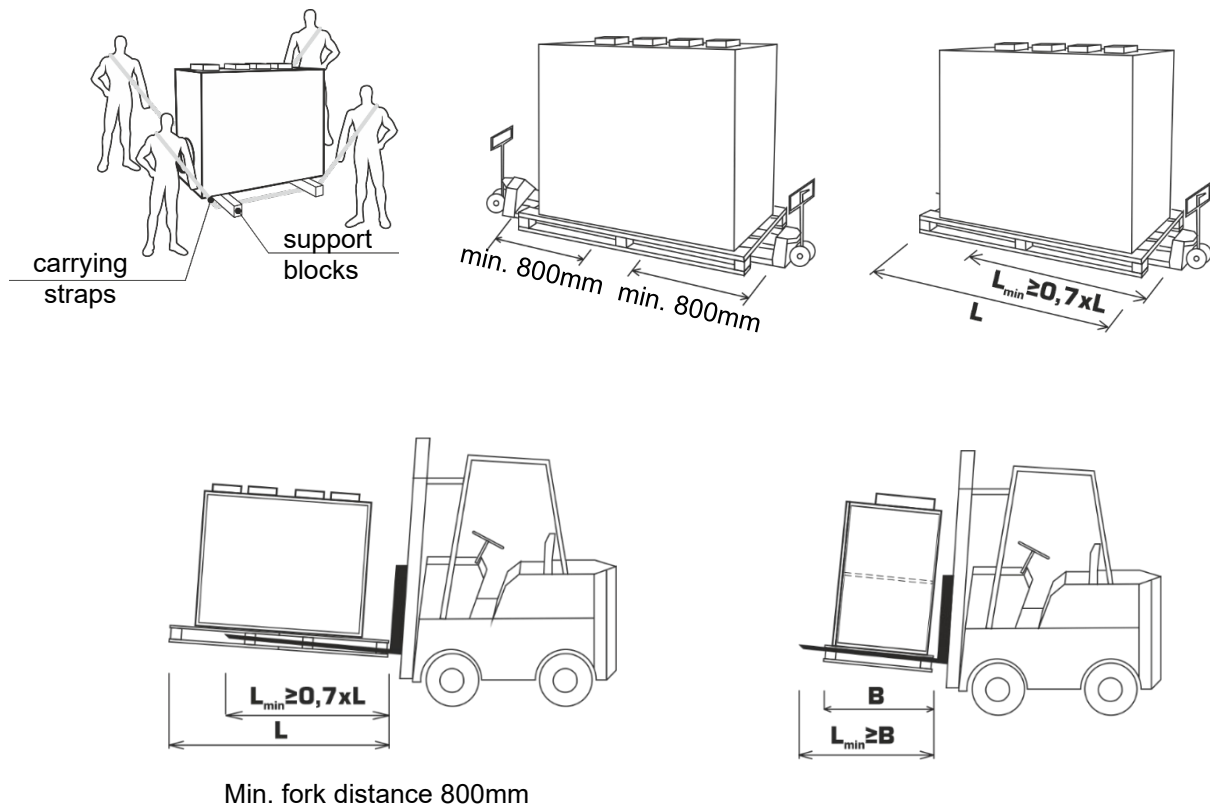

When lifting a pallet, make sure that the wheels of the pallet truck are not on the pallet crossbars to prevent them from breaking and damaging the pallet

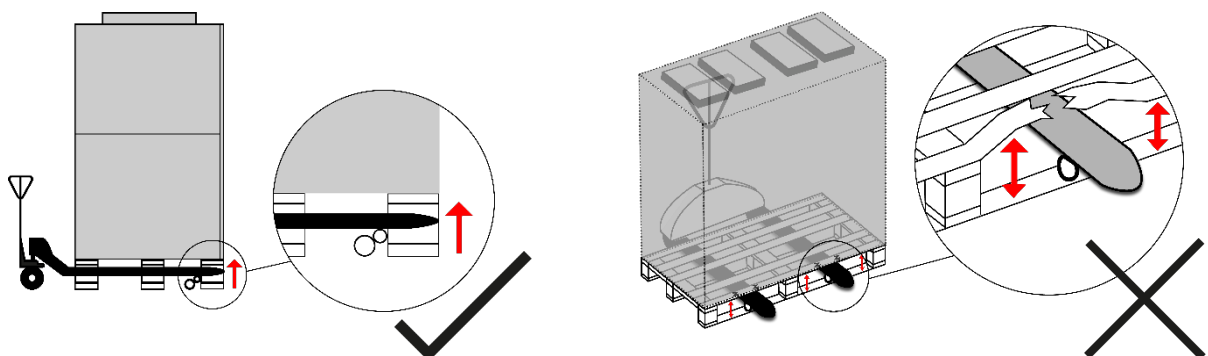

4 Description

4.1 General

DUPLEXbase PT series ventilation units with heat recovery are compact appliances containing in a single cabinet two independently powered fans with flexibly mounted engines, a highly efficient heat recovery exchanger assembled from thin-walled plastic boards for the recovery of heat/cool, a by-pass damper, slide-out filters and drainage trays, and depending on accessories selected also an integrated heater, chiller, shut-off dampers, flexible flanges and a control system.

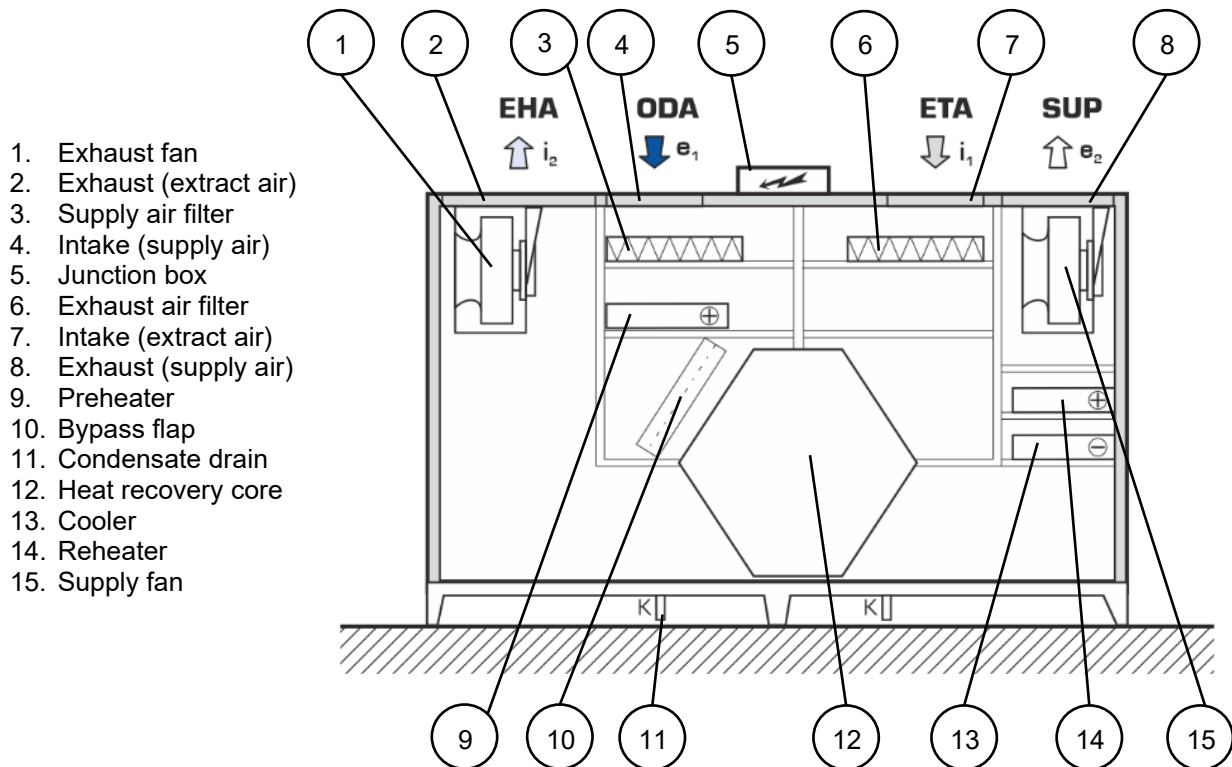

4.2 Intended use

DUPLEXbase PT series ventilation units with heat recovery are intended for the comfort ventilation and possibly hot-air heating and cooling of flats and houses, small plants, workshops, schools, restaurants, cooking facilities and industrial halls or for similar applications with a basic environment.

DUPLEXbase PT units meet requirements of Commission Regulation (EU) No. 1253/2014 (Ecodesign) in the defined working area

5 Installation

5.1 Safety instructions

- During installation make sure no damage or deformation is caused to the casing of the appliance (e.g. as a result of handling operations).
- After setting the appliance in place check it for stability and secure it in this position against moving.
- During handling and installation observe all rules of safe work (including work at heights and work with suspended loads) and use appropriate work and safety equipment.
- Lifting and binding equipment may only be operated by trained personnel.

5.2 Hygienic instructions and requirements

- If installation is interrupted or heavy dusting occurs, cover all openings of the appliance in such a way so as to ensure that surfaces to be in contact with transported air remain protected against the weather and stay clean and dry.
- If long-term high relative humidity (short-term more than 90 % or more than 80 % for three consecutive days) is likely to occur with the subsequent moistening of filters (e.g. in areas with frequent fogs, frequent and long rains, flying snow etc.), suitable measures must be taken to prevent microbiologic growth. Recommended measures include more frequent hygienic checks as per VDI 6022 or shorter filter replacement intervals. Another option is the preheating of air using an appropriate control devices, or the appliance must be put out of operation for the period when filters are at the risk of moistening (if the type of operation allows this).
- Should such weather conditions occur at the site of installation that would cause the dew point to be exceeded in the supply air region of the heat recovery exchanger, or an independent cooling system is installed in ventilated rooms, DUPLEXbase PT units may only be used provided that it has been arranged via appropriate measures that the dew point will not be exceeded in the heat recovery exchanger. The typical weather of central Europe makes this condition almost impossible.
- The e1/ODA air supply chamber has no water drain. An accessible and cleanable chamber with a drain of precipitated water must be installed upstream the outdoor air inlet into the appliance.
- The HVAC network of appliances operated in an environment with Class ETA 2 extract air must be arranged for operation in such a way so that positive pressure is on the supply air side downstream the heat recovery unit; in an environment with Class ETA 3 extract air the HVAC network must be arranged for operation in such a way so that positive pressure is on the supply side against the exhaust side. This must be ensured under all operating conditions of the system. For details see EN 13779.
- In compliance with hygienic standard VDI 6022 HVAC systems must be equipped with shut-off dampers to ensure the automatic closure of the system so that no air can flow freely through the system. Shut-off damper of the fresh air supply (ODA) must be thermally insulated. It is recommended using shut-off dampers available as an accessory. It is the responsibility of the planner / specialist installation firm to comply with this requirement.
- DUPLEXbase PT series appliances have a single-stage filtration system. Appliances in a hygienic version in compliance with hygienic standard VDI 6022 must have at least Class ISO ePM1 50% (F7) filter fitted on the inlet (applies to outdoor air e1/ODA Class ODA 1 and ODA 2). When outdoor air is Class 3, a Class ISO ePM10 50% (M5) filter must be fitted in the duct upstream the outdoor air inlet into the HVAC unit; alternatively, a Class ISO ePM10 50% (M5) filter may be installed in the HVAC unit and a Class ISO ePM1 50% (F7) filter in the duct at the e2/SUP outlet from the unit. Note: air filters ISO ePM10 50% (M5), ISO ePM1 55% (F7) and ISO ePM1 80% (F9) are separately supplied accessories.
- Appliances in a hygienic version in compliance with hygienic standard VDI 6022 may be operated only if the use of recirculating air is suitable for hygienic reasons or the arrangement of operation of the HVAC network ensures positive pressure in the supply section of the appliance against the extraction section.

5.3 Configuring orientation of the unit

Versatile design of DUPLEXbase PT in sizes 500, 900, 1800, 2800 and 3500 allows adjusting the direction of air flow through the appliance; it can be configured which of the fans will be supplying and extracting the air. The direction of air flow can be configured once the unit is switched ON for the first time.

5.3.1 RD6 (aMotion) control system

1. The fans are marked with labels such as M1 and M2 at the factory. You can also refer to the position of the M1 and M2 fans according to the drawings:

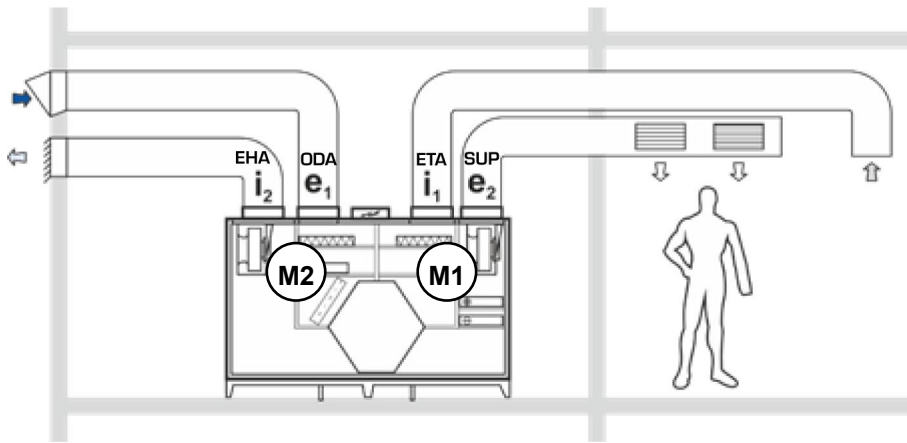

Key:
 e1 (ODA) – intake
 (supply air)
 e2 (SUP) – exhaust
 (supply air)
 i1 (ETA) - intake
 (extract air)
 i2 (EHA) – exhaust
 (extract air)

Position of intake and exhaust, M1 is configured as a supply fan (M-SUP)

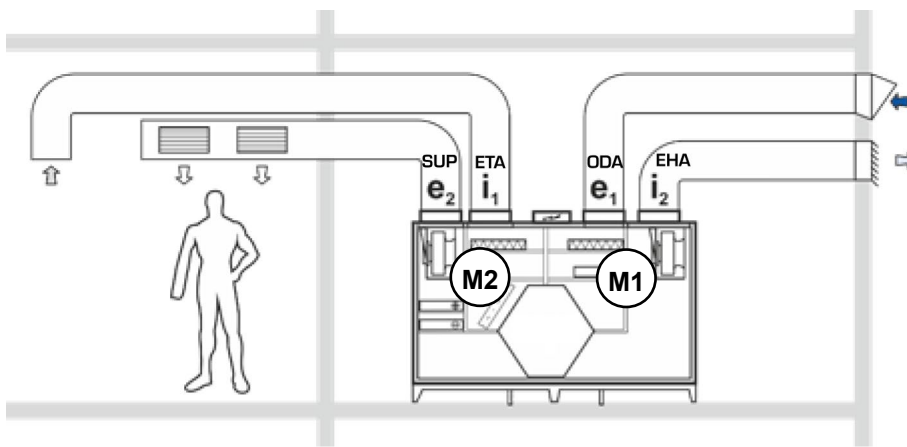

Position of intake and exhaust, M2 is configured as a supply fan (M-SUP)

2. Connect to the unit using an Ethernet cable and the aTool service program. The program is available to trained service technicians.
3. Select **Service Settings** > **Parameters** and select the **Fans** subgroup
4. Select whether the supply fan (M-SUP) will be M1 or M2 (parameter 2113).

Device information Communication Device manager Backup **Service setting** Commissioning Boards connection

The panel contains service and configuration parameters

Parameters Configuration check The boards allocation Programmable inputs Setting of the functions Temperature corrections

Q m-sup

Nondefault Heating **Fans** Circulation Topology Support Function Cooling Heat Pump Preheater Sensors Bypass HRC

Dehumidification VAV End-user

Id	Title	Value	Minimum	Maximum	Default
p_2113	Fans - M-SUP orientation	M1			Unset
p_2254	Fans - M-SUP correction	Unset	-80 %	80 %	0 %
p_2356	Fans - M-SUP correction for all regimes	M2			OFF

- ! The operation of the unit is blocked until the parameter 2113 is configured to M1 or M2.
 - Identify the individual connection ports and mark them with labels (included in delivery) according to the set orientation.
- After each change in the unit's orientation, make sure that the supply and exhaust air filters are installed at the supply and exhaust points. For more information, see Chapter 5.7.

5.3.2 RD5 control system

- Connect the control panel CP Touch to the unit. Turn the unit ON. The control panel will report an error by showing a yellow triangle on the top of the display.
- Click on the symbol of the error. The control panel will display the message *Orientation is not set*.
- Proceed back to the default screen, click on the cogwheel in the bottom left corner.
- Click on the Settings symbol in the top right corner.
- Enter the service menu password. The password is available to authorized partners.
- Proceed to the parameter 3.2.2 on the control panel. Set up the fan M1 or M2 as M-SUP (supply fan). The position of fans M1 and M2 is shown on drawings above. Fans in the unit are also marked by labels M1 and M2.

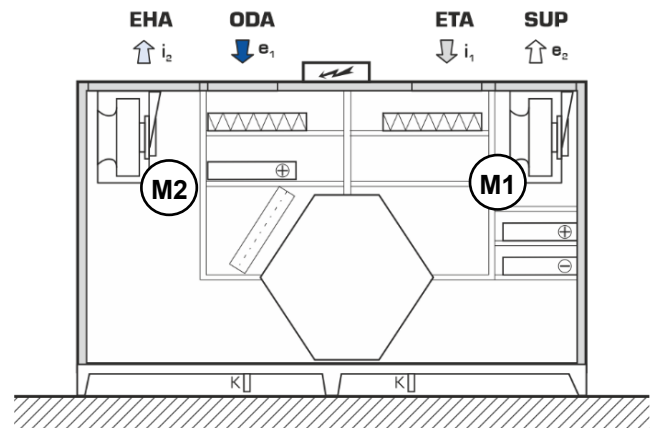
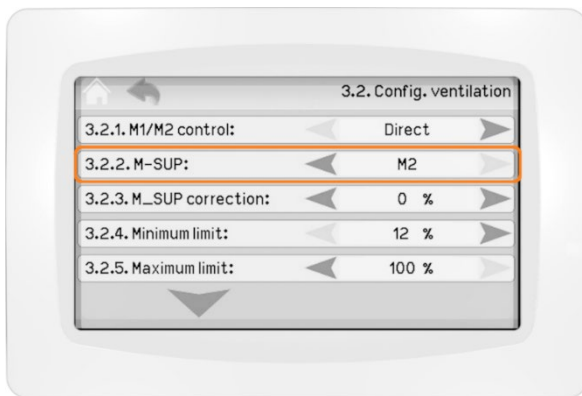

! The operation of the unit is blocked until the parameter M_{SUP} is configured to M1 or M2.

- Identify individual ports based on the configured unit orientation and mark the ports by labels (part of delivery).
- After each change of unit orientation make sure that the filters of supply air (resp. extract air) are positioned in the supply (resp. extract) section of the unit. For more information see Chapter 5.7.

5.4 Installation

- Before installation remove the wooden transport planks.
- Fit the appliance in such a way that the prescribed handling spaces are observed:

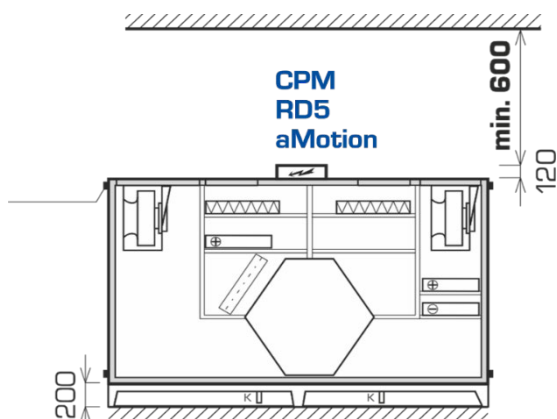

View from the operator's side

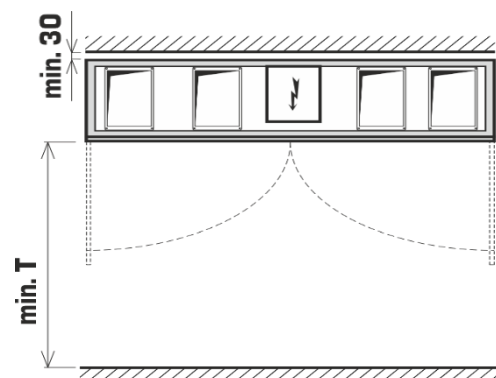

Floor plan view

DUPLEXbase PT	500	900	1800	2800	3500
T (mm)	600	600	1100	1100	1100

- The appliance is placed on height-adjustable stand feet included in delivery (4 pcs in sizes 500 and 900, 6 pcs in size 1800, 2800 and 3500).
- Level the appliance horizontally on both longer and shorter side. Use adjustable stand feet.

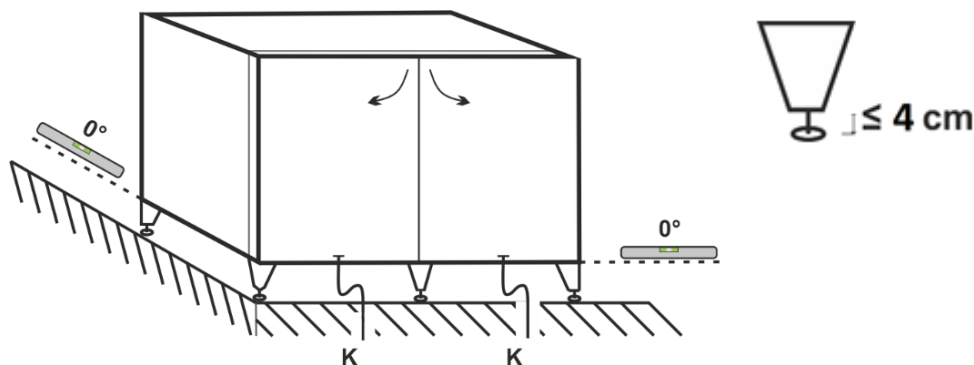

- ! Adjustable bases must be fully screwed into the stand feet when manipulating with the unit. Only after putting the unit into the final installation position may the feet height be adjusted. Failing to do so may cause irreversible damage of the feet.
- The unit must be secured against movement.

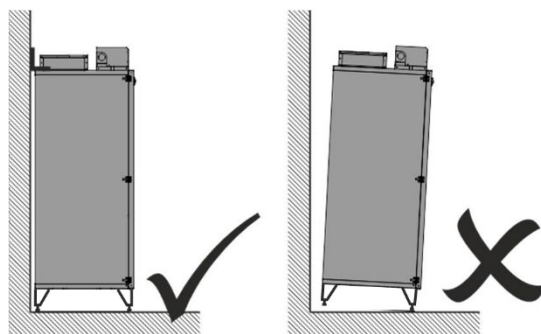

5.5 Ductwork connections

- Connect the HVAC duct following the design documentation. Make sure that the air exhausted at i2 (EHA) does not return back to the fresh air supply e1.
- Air duct must be connected to inlet ports in a way that a uniform flow rate is achieved in the whole cross-section of inlet ports.
- A straight air duct being at least 1 m long must be firmly connected to extraction ports to achieve a uniform flow rate in the whole cross-section of extraction ports.
- A duct being at least 2 m long must be always connected to fan outlets to prevent injury caused by the fan's impeller. This duct must be connected in such a way that it can be dismantled only by using tools.

5.6 Connecting the condensate drain pipe

- The unit is equipped by two condensate outlets; these are used depending on whether an integrated cooler is installed and what unit orientation is selected.

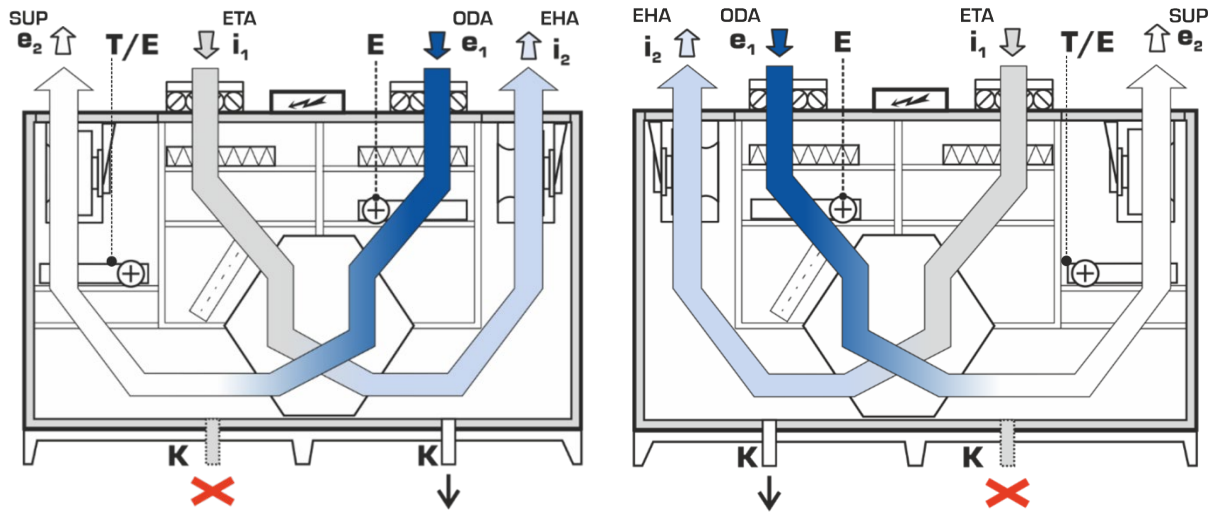

Use of condensate drains, DUPLEXbase PT without integrated

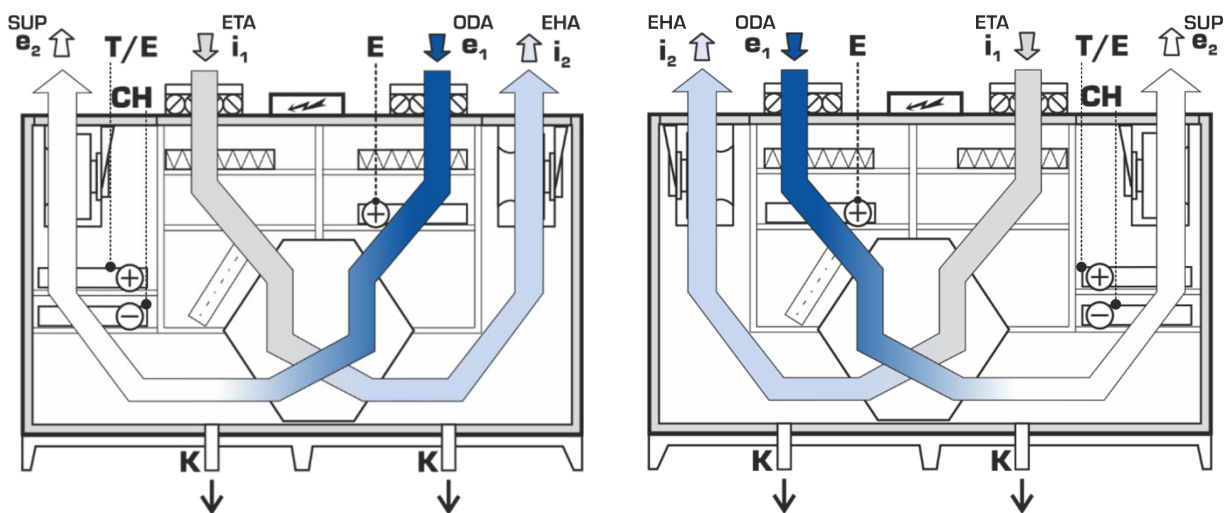

Use of condensate drains, DUPLEXbase PT with integrated

Siphon height

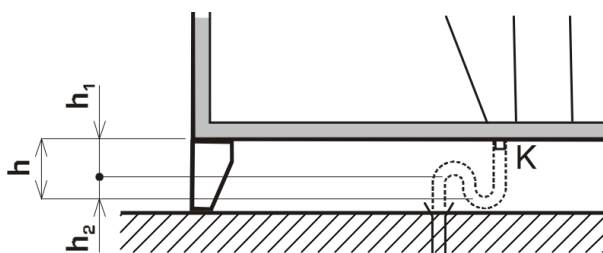

$$h_1 = \frac{\Delta p}{10} + 50 \text{ [mm]}$$

$$h_2 = \frac{\Delta p}{2 \cdot 10} + 50 \text{ [mm]}$$

$$h = 1,5 \frac{\Delta p}{10} + 100 \text{ [mm]}$$

Δp – maximum positive / negative working pressure in the compartment of the unit. The height of condensate drain pipe $h = 15$ cm, and $h_2 = 6$ cm is sufficient for vast majority of installations.

- Connect one siphon trap (included in delivery) to each condensate outlet. Connect the siphon to the sewer line.
- Make sure that the condensate pipe is passible all the way along including parts inside the unit and the pipe slope is sufficient.
- Fill each siphon trap with water.

5.7 Installing air filters

The unit is supplied with separately packed filter cassettes. Filters of outdoor and extracted air feature different filtration class in the default configuration:

- Filter with the class ISO ePM1 55% (F7) is the filter of outdoor air and it is placed in the compartment e1 (ODA);
- Filter with the class ISO ePM10 50% (M5) is the filter of extracted air and it is placed in the compartment i1 (ETA);

i Filter with the class ISO ePM1 80% (F9) can be supplied as spare filtration cassette.

- Remove, unpack the cassettes and check their condition. Then install the cassettes in their correct location based on the unit orientation, see pictures in the Chapter 5.3.
- ➔ **Unpack and install air filters last, immediately before putting the unit into service to avoid their contamination.**
- Should any damage or contamination be detected, replace the filters with new ones. Spare filter cassettes can be ordered from the supplier. The supplier's address and the spare cassette part number are shown on the identification plate of the unit.
- Insert undamaged clean filters into the guide rails and secure them.



- ! Specially make sure that the arrow showing the direction of air flow through the filter cassette can be seen from the side of the operator (the arrow is by the unit's door) and that the arrow always points towards the heat recovery exchanger!
- The unit is supplied with filter cassette labels unattached. Attach the relevant identification labels near both filters (e.g. on respective unit door).

! Unpack and install air filters last, immediately before putting the unit into service to avoid their contamination.

! Use original filter cassettes only! If different cassettes were used, the manufacturer cannot guarantee their proper function!

➔ **Record the date of installing filters appropriately in e.g. the operational logbook.**

5.8 Installing and connecting filter manometers

- ➔ **Filter manometers are a separately supplied accessory. Manometers are compulsory for hygienic units in compliance with VDI 6022.**
- Manometers are used for measuring the pressure loss of air filters. During installation follow the visual instructions supplied with this optional accessory.

- Connect the manometers to collection points on the unit's surface using tubes. Connect the tube to the top / side of the manometer and run it to the metal bushing on the unit's surface (also see a separate manometer installation manual). The tube must always connect two matching connection points identified by symbols "+" and "-" (cannot be combined). Make sure that tubes from just one filter are connected to the manometer.
- Attach the relevant label near each manometer. On the label, fill out the flow rates and pressure losses of the clean filter (initial pressure loss) and when clogged (final pressure loss) using data from the table below; the values must be adjusted on the basis of actual air flow rates through the unit. An unattached blank label is included.

DUPLEXbase PT 500

Filter type	Flow rate (m ³ /h)	100	200	300	400	450
ISO ePM1 55% (F7)	Initial pressure loss (Pa)	18	45	78	120	144
	Final pressure loss (Pa)	200	200	200	200	200
ISO ePM10 50% (M5)	Initial pressure loss (Pa)	5	17	36	62	78
	Final pressure loss (Pa)	200	200	200	200	200

DUPLEXbase PT 900

Filter type	Flow rate (m ³ /h)	400	500	600	700	800
ISO ePM1 55% (F7)	Initial pressure loss (Pa)	58	78	100	124	150
	Final pressure loss (Pa)	200	200	200	200	200
ISO ePM10 50% (M5)	Initial pressure loss (Pa)	15	23	33	44	58
	Final pressure loss (Pa)	200	200	200	200	200

DUPLEXbase PT 1800

Filter type	Flow rate (m ³ /h)	800	1000	1200	1500	1800
ISO ePM1 55% (F7)	Initial pressure loss (Pa)	13	21	30	47	68
	Final pressure loss (Pa)	200	200	200	200	200
ISO ePM10 50% (M5)	Initial pressure loss (Pa)	2	4	5	8	11
	Final pressure loss (Pa)	200	200	200	200	200

DUPLEXbase PT 2800

Filter type	Flow rate (m ³ /h)	800	1000	1500	2000	2200	2500
ISO ePM1 55% (F7)	Initial pressure loss (Pa)	13	18	31	48	55	67
	Final pressure loss (Pa)	200	200	200	200	200	200
ISO ePM10 50% (M5)	Initial pressure loss (Pa)	3	4	8	12	15	18
	Final pressure loss (Pa)	200	200	200	200	200	200

DUPLEXbase PT 3500

Filter type	Flow rate (m ³ /h)	1000	1500	2000	2500	3000	3500
ISO ePM1 55% (F7)	Initial pressure loss (Pa)	10	13	24	30	47	64
	Final pressure loss (Pa)	200	200	200	200	200	200
ISO ePM10 50% (M5)	Initial pressure loss (Pa)	2	4	6	11	15	22
	Final pressure loss (Pa)	200	200	200	200	200	200

Note: Values in the tables apply to external static pressure 200 Pa. Different pressure requirements may result in a different situation. If needed, the detailed initial and final pressure loss data of the filters are available on request from the supplier of the unit.

- Make sure that the position of the label makes it possible to regularly inspect the values recorded.

When using inclined fluid manometers

- Unscrew the rotating knob as much as possible to set zero on the scale (the bottom knob identified by - +), then screw it back by approximately two full turns to have leeway to make settings in both directions.
- Unscrew the FILL plug (the top knob) and keep filling the machine with measuring liquid (included in delivery) until the liquid is visible near the zero mark on the scale. Use the bottom knob to set the value on the scale precisely to zero. Screw the top filling plug in.

- ! After installing the manometers do not tilt the machine or the door (if they are installed on the door). Measurement liquid might leak out.

5.9 Installing hot water heating coil

During the mechanical installation of the hot water air heater follow the manual supplied with this optional accessory.

The following rules must be adhered to during the installation of the water heater:

1. The device may only be operated if the heating system including the hot water heater and hydraulic kit are filled with a heating medium and air bled; also applies to periods outside the heating season!
2. The unit must have continuous hot water supply during the heating season.
3. The unit must be permanently connected to power supply to provide for the anti-freeze protection of the hot water heater. In the case of a prolonged power outage the heating medium must be drained from the hot water heater including the hydraulic kit; this does not apply when antifreeze mixture with sufficient temperature resistance is used. We recommend draining water from the heater with pressurized air, not using a gravity flow!
4. Once the coil is drained the ventilation unit can be operated this way for up to one month. Later, there is a risk of corrosion on inner parts of the coil.
5. The maximum permitted temperature of heating medium is 110 °C and operational positive pressure up to 1.0 MPa.
6. For the proper operation of the hydraulic kit of the hot water heater the heating system must be fitted with a circulation pump of suitable power that will fully cover its pressure loss. The pump, which is supplied with the hydraulic kit, is designed solely to cover the pressure loss of the water heater!
7. If the unit is not equipped with a shut-off damper on outdoor air inlet e1 (ODA), a tight, thermally isolated shut-off damper must be installed in the duct upstream the unit (a type with a servo drive with emergency stop is recommended, i.e. with automatic shut-off in the event of a power outage).
8. The heating system must be equipped with a sludge filter in the inlet into the unit.
9. The heating circuit must be equipped by a safety valve and a sealed pressure vessel. Heat carrier – untreated water or water treated as per the rules below, properly bled. Fluid with antifreeze protection (e.g. ethylene glycol) can be used as heat carrier if necessary. We recommend isolating the inlet and outlet piping.

- ! Electrical installation may be carried out only by a person having the required electrotechnical qualification.

- ! When operating the unit without active heating, a lower supply air temperature must be expected, which may limit the thermal comfort

The supply (and top-up) water should fulfil especially the following criteria:

- The water must be limpid and colourless.
- The pH value of water must not be lower than 7. If water contains dissolved neutral salts its pH value is to be between 8,5 and 9,5. Soda lye or trisodium phosphate (Na_3PO_4) can be used for alkalisation.
- The content of carbon dioxide in an ion and non-ion form is to be as small as possible.
- Recommended water hardness in the range of 7–12 °dH. The remaining supply water hardness should be lower than 7 mmol/l (at $q < 23 \text{ kW/m}^2$) and 5 mmol/l (at $q > 23 \text{ kW/m}^2$). To soften the water, the following chemicals can be used: trisodium phosphate Na_3PO_4 or cation-exchange resin

(in case water is harder than 7 mmol/l; circuits with high volume of water; when electrical boilers and radiation boilers are present).

- The amount of calcium ion in the water up to 3,5 mmol/l (at $q < 23 \text{ kW/m}^2$) and up to 1,8 mmol/l (at $q > 23 \text{ kW/m}^2$).
- All CO_2 up to 75 mg/l (at $q < 23 \text{ kW/m}^2$) and 10 mg/l (at $q > 23 \text{ kW/m}^2$).

 You will find the wiring diagram in the unit's Technical Specification or in the selection SW of DUPLEXbase units, tab **Controls > Wiring diagram**.

5.10 Installing mixing valve of hot water air heater

During the mechanical installation and connection of the mixing valve of the hot water air heater follow the manual supplied with this optional accessory.

5.11 Installing shut-off dampers e1, i1

During the mechanical installation and connection of the servo drive of shut-off dampers follow the manual supplied with this optional accessory.

5.12 Installing flexible flanges

During the mechanical installation of flexible flanges follow the manual supplied with this optional accessory.

5.13 Installing and connecting water chiller to the cool source

- During the mechanical installation of the water chiller follow the manual supplied with this optional accessory.

The following rules must be adhered to during the installation of the water chiller:

- The water chiller in all versions must be filled with an antifreeze mixture with sufficient thermal resistance, or it must be drained as long as the outdoor temperature might drop below 3°C . We recommend draining water from the chiller with pressurized air, not using a gravity flow!
- Maximum permitted operating positive pressure is 1.0 MPa!
- The inlet of the chilled water system into the unit must be equipped with a sludge filter.

5.14 Installing mixing valve of the water chiller

During the mechanical installation and connection of the control manifold of the hot water heater follow the instructions supplied with this optional accessory.

5.15 Installing direct chiller

- During the mechanical installation of the direct chiller follow the manual supplied with this optional accessory.
- During the connection of the direct chiller follow the instructions of the supplier of condensation units and connecting pipes.

5.16 Installing electric heater / pre-heater

- During mechanical installation and electrical connection follow the manual supplied with this optional accessory.
- Electrical connections may only be made by a qualified electrician authorized to service power supply networks.

5.17 Installing manometers to control constant flow and constant pressure

During mechanical installation and electrical connection follow the manual supplied with this optional accessory.

6 Electrical connection

1. The electrical equipment of the unit is designed by following standards in effect for electrical connections to power supply network TN-C, TN-S, TN-C,S. The appliance may only be connected by a qualified electrician. The appliance is provided with external connections for equipotential bonding.
2. The characteristics of the mains voltage must comply with EN 50160 and the defined standardized voltages according to IEC60038.
3. The wiring diagram of the equipment is shown in the documentation supplied along with the unit. Instructions for and the diagrams of electrical connections of optional accessories are included in the documentation sets of these accessories.
4. The power supply line to the equipment must be provided with a disconnecting device - a service switch for disconnecting from power supply - the opening contacts of which are at least 3 mm apart at all poles. This disconnecting device must be installed within an appropriate distance from the appliance. The protection device included as a standard with delivery may act as such a disconnecting device provided that the switchboard is located within reach of the appliance.
5. Protection of the unit from the strike of flash must be carried out according to EN 62305-3 Physical damage to structures and life hazard. If the outer containment equipment does not protect the unit from direct strike of flash it is necessary to connect the conductors leading the flash currents to conductors that come from the unit into the premises. The purpose is to limit the intrusion of partial flash current into the premises.
6. Commissioning may vary depending on the type of control system. Commissioning is carried out by a trained technician following the separate documentation set included.
7. The controls are described in a separate guide on operating the control system.

- ! The unit is to be protected using a breaker with characteristics "**C**".
- In case of using additional overcurrent protection against accidental direct or indirect contact, it is necessary to use a **special** circuit breaker designed for frequency inverters and switching sources. It is a protector sensitive to alternating pulsed DC residual currents, resistant to current surges 5 kA.

7 Unit commissioning

7.1 Safety instructions

Before putting the unit into operation, it is necessary to:

1. Carefully inspect the unit;
2. Obtain the initial or latest valid inspection report for the power supply to the equipment. A written document must be issued for this inspection. Next, fill out the commissioning report and familiarize the operator with the equipment;
3. Air ducts must be securely connected to the device's outlet and inlet ports according to the instructions provided in the previous chapters;
4. Filling the siphon for condensate drainage with water;
5. Fill the heating circuit, including the hot water heater and hydraulic kit (this also applies to external hot water heaters in air duct equipped with a hydraulic kit), with heating medium, even outside the heating season. When filling the circuit, it is necessary to check that the shut-off valves at the inlet and outlet of the heating medium to the heater are open and to ensure that the system is vented;
6. Devices with a hot water heater (this also applies to external hot water heaters in pipes equipped with a hydraulic kit) must be permanently connected to the power supply to ensure frost protection for the hot water heater. In the event of a prolonged power outage during the season when temperatures drop below 3°C, the heating medium must be drained from the hot water heater, including the hydraulic kit. We recommend draining the heating medium from the heater using compressed air, not gravity!
7. After commissioning, the unit must be operated at least intermittently (the unit must run for at least 1 hour per day).

7.2 Hygienic instructions for compliance with VDI 6022

7.2.1 General instructions

- Basic hygiene-related requirements are outlined in the Chapter 5.2.
- The appliance has been manufactured in a hygienic design that complies with all requirements of the VDI 6022 standard for the hygiene of HVAC device. In order to meet those requirements during operation it is essential to ensure for the appliance to be operated, maintained, inspected and cleaned by sufficiently qualified personnel in accordance with instructions contained in the operation and maintenance manual. It is also essential to ensure for the remaining components of the HVAC system (HVAC distribution systems, distribution elements, ancillary devices, noise silencers etc.) to meet all hygienic requirements of the VDI 6022 standard and be operated in compliance with those requirements.
- Before commissioning or if the appliance has been out of operation for a longer period of time, it must be cleaned thoroughly; if stricter hygienic requirements apply, wiping disinfection must be carried out.
- After carrying out disinfection measures, it is necessary to ensure that no toxicologically suspicious or odour-active substances enter the supply air.
- If long-term high relative humidity (short-term more than 90 % or more than 80 % for three consecutive days) is likely to occur with the subsequent moistening of filters (e.g. in areas with frequent fogs, frequent and long rains, flying snow etc.), suitable measures must be taken to prevent microbiologic growth. Recommended measures include more frequent hygienic checks as per VDI 6022 or shorter filter replacement intervals. Another option is the preheating of air using an appropriate control devices, or the appliance must be put out of operation for the period when filters are at the risk of moistening (if the type of operation allows this).
- Air duct including accessories with autonomous regulation of operation is to be connected on the fresh air supply. Such duct will, in compliance with the regulation VDI 6022, provide for appropriate treatment of supplied fresh air to prevent air filter from getting wet. In case the duct is not connected or if it does not include such accessory, the appliance is to be put out of operation as long as the risk of air filters to get wet persists (thick fog, snowing).
- Operators must be familiar with the tasks and functions as well as the individual components of the appliance.
- The appliance must be regularly inspected, cleaned and maintained by sufficiently qualified personnel (see the following chapter).
- Regardless of their qualifications, personnel must undergo hygiene training (see the following chapter).
- The user must be able at any given time to provide evidence as to the qualifications of operators. If sufficient number of qualified operational and service staff are not available, those activities must be commissioned to a specialist company that will be responsible for the proper operation of the appliance.
- The user has an obligation to carry out regular hygiene inspections of the appliance every 3 years (see following chapters).
- The appliance must not be operated without air filters. The filter grade of supply fresh air must be at least ISO ePM1 50% (F7). The filter grade of exhaust air must be at least ISO ePM10 50% (M5).
- After disinfecting make sure that no toxicologically suspicious or odour-active substances enter supply air!
- The permanent low-frequency noise level (10 to 100 Hz) generated by the appliance must not exceed the audibility threshold. The value to be applied as guidance is that the low-frequency level of acoustic pressure LCF should not exceed the value of acoustic pressure LAF by more than 20 dB (see DIN 45680). In case of doubt a frequency analysis of the low-frequency value of acoustic pressure must be carried out in order to make it possible to identify and suppress the source of the narrow band of the faulty zone.
- The user has an obligation to appropriately record the appliance's operation (e.g. in the operational logbook).

7.2.2 Required qualifications of personnel as per the type of activity

Activities	Operators	Inspection	Maintenance	Repairs
Required personnel qualifications	No special professional qualifications	Professional engineering qualifications in building maintenance, familiarity with measurement procedures for the hygiene inspections of HVAC devices	Professional qualifications in electrical or metal engineering with relevant experience in the field of HVAC (familiarity with equipment design, measurement technologies, equipment control and function)**	
Required hygiene training of personnel	Category B	Category A	Category B	
** simple inspection and maintenance of the equipment (e.g. replacing filter cassettes, regular cleaning of equipment etc.) may be carried out by personnel without professional qualifications who received category B hygiene training				

a) Category B hygiene training of personnel

⇒ Personnel must demonstrate familiarity with the following areas:

- (1) Need for and the importance of hygiene during the operation of HVAC equipment
- (2) Hygiene issues of individual aggregates carrying air through HVAC equipment
- (3) Maintenance of HVAC equipment, the effects of its size on determining maintenance intervals
- (4) Simple measurement methods for checking HVAC equipment
- (5) Actions to be taken in the case of occurrence of substances harmful to the environment and their removal
- (6) Personal protective measures in the area of hygiene during operation and service activities
- (7) Key regulations (regulations on accident control) and technical standards
- (8) Handling chemical cleaning and disinfecting agents

b) Category A hygiene training of personnel

⇒ Personnel must demonstrate familiarity with the areas of category B training specifications and additionally the following:

- (1) Hygiene basics
- (2) Significance of the various hygienic methods of air treatment
- (3) Physical and chemical measurement methods, hygiene and microbiological inspection methods
- (4) SBS (Sick-Building-Syndrome) issues, symptoms of problems and possible causes
- (5) Technical development and its practical applications
- (6) Hygiene regulations and technical rules for the operation of HVAC equipment

If these instructions are not adhered to, the manufacturer cannot guarantee the permanent maintenance of the unit's hygiene parameters.

7.3 Protection of idle unit

1. During any shutdown, or after installation of the unit until it is put into operation, the unit must be treated as stored equipment in accordance with the conditions in Chapter 3, otherwise there is a risk of, among other things:
 - Corrosion of the inner casing, fans, and other metal parts due to the ingress of air humidity;
 - Mold on filters;
 - Damage to electrical equipment due to the ingress of air humidity;
 - Damage to electrical equipment when connected to the electrical system.
2. The unit must be commissioned and **put into operation within two months from its installation.**
3. Protect the unit from the ingress of dirt. If installation is interrupted or if there is a lot of dust, all openings in the equipment must be covered so that the surfaces that will be in contact with the transported air remain protected from the weather, dry, and clean.

4. Do not operate the units during construction work. Switch off the unit before starting construction work and cover all ends of the pipe distribution system. The unit must be treated as stored equipment (see Chapter 3) until all construction work has been completed and all construction debris and dust has been cleaned up.
5. Protect the units from cooling down, unwanted air flow, and condensation on internal surfaces (e.g., chimney effect or when a new building is drying out). Close the manual shut-off dampers on the supply e1 (ODA) and exhaust i1 (ETA) of the unit, and place shut-off dampers in the ductwork to prevent free air flow.

8 Unit control

8.1 Control system RD6 (aMotion)

Ventilation units DUPLEXbase PT equipped with control system RD6 (aMotion)¹ can be controlled from computer via a direct connection or in local network, both via the Ethernet connection. At the same time, the RD6 (aMotion) Cloud **aSpace** can be used.

Upon establishing connection to the unit, it is possible to:

- Change user settings of the unit;
- Watch the unit's operational parameters including error messages;
- Browse the unit's operational history.

8.1.1 Connection via ethernet interface



Ventilation unit is connected to a computer by cable via ethernet interface

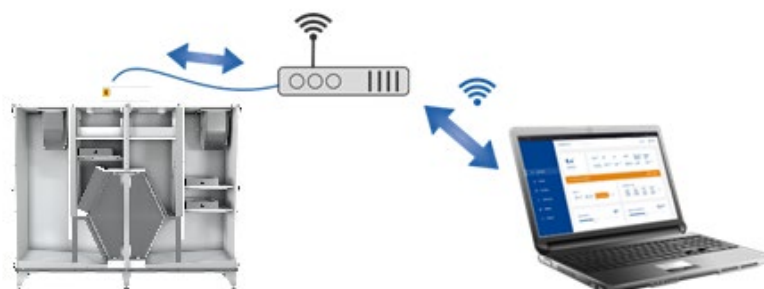

Ventilation unit is connected to a local network via ethernet interface, computer is connected to the same network

- ! Ethernet connector RJ45 must not be connected to the Ethernet network operated with PoE (Power over Ethernet).

¹ Information regarding the control module your unit contains is shown on the unit's name plate on the Controls / Specification line. The information is also included in the unit's Technical Specification

8.1.2 RD6 (aMotion) cloud

RD6 (aMotion) cloud (aSpace) allows for remote connection to the DUPLEXbase unit using the Internet. Once the connection is established, the user interface of the unit is displayed in the web browser. Communication takes place via a secure protocol.

Steps to connect via RD6 (aMotion) Cloud:

1. Add user to the unit
 - a. Connect to the DUPLEXbase unit directly from the computer or via local network;
 - b. In the menu **Settings > User management** add a user with the same email address as you will be using for connection via RD6 (aMotion) Cloud;
2. Login to RD6 (aMotion) Cloud at [RD6 \(aMotion\).cloud](https://rd6.aMotion.cloud). You will see the unit in the list of available devices.
3. Connect to the unit.

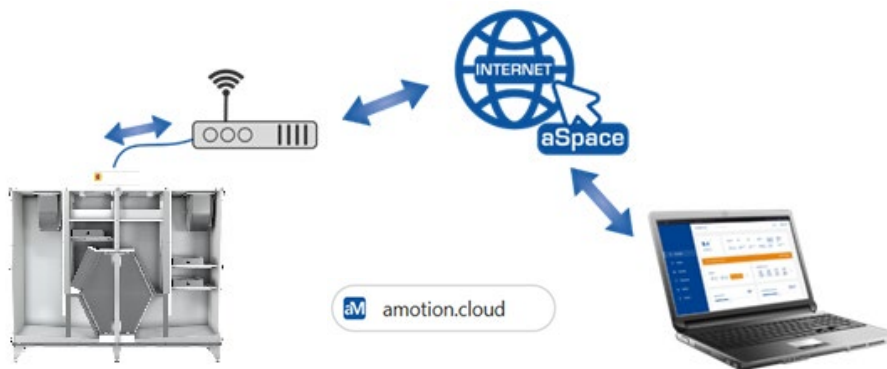

*Ventilation unit is connected to local network with access to the internet, computer uses Cloud **aSpace** for communication*



DUPLEXbase units with RD6 (aMotion) control have factory default settings that enable connection to **aSpace cloud** and automatic firmware updates via an internet connection. These settings can be changed by the user at any time.

- Cloud connection in the **Settings > Cloud Connection**;
- Automatic update in the **Settings > System**.

You will find more information in the Guide on controlling ventilation units DUPLEXbase equipped with RD6 (aMotion) control system.

- ! Ethernet connector RJ45 must not be connected to the Ethernet network operated with PoE (Power over Ethernet).

8.1.3 Mobile application

Units with RD6 (aMotion) control system can be controlled directly from the mobile app. In order for the unit to appear in the device list, you need to add user to the unit, see the previous chapter. You can also add units from the local network.

Once connected to the unit, you have access to a user interface with unit operation monitoring, scene settings, calendars and a range of other parameters. The app is available for Android and iOS operating systems.

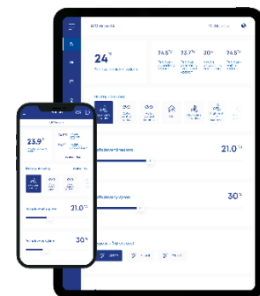

8.2 Control system RD5

The ventilation units equipped with control system RD5 can also be controlled using a web browser. This allows the user to do the following, either from a local network on site or through the Internet:

- Change user setting of the unit;
- Watch the unit's operational parameters including error messages;
- Browse the unit's operational history;
- Set e-mail notification with Alarm or Warning messages for up to three e-mail addresses.

You will find more information in the Guide on controlling ventilation units DUPLEXbase equipped with RD5 control system.

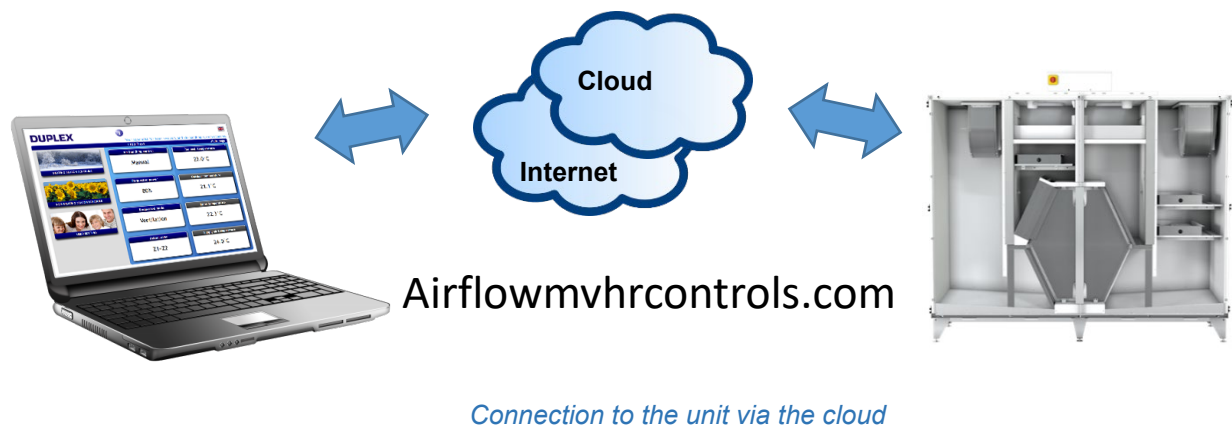

9 Package disposal

Materials marked with the symbol  are recyclable. Put these materials in the respective bins in order to be recycled.

PAP – corrugated cardboard
FOR – wood

PE – polyethylene
PS – polystyrene

PP – polypropylene

Please leave materials marked with the  symbol at the community place used for waste disposal!

Disused ventilation unit sold on the EU market can be recycled in compliance with the regulation 2012/19/EU. For further information please contact your distributor.

Internet address of guide on disassembly in compliance with the Commission Regulation (EU) 1253/2014: www.airflow.com.



10 Repairs, spare parts

All warranty and post-warranty repairs are performed by the supplier or an authorized service company.

11 Warranty

The product is covered by warranty according to Terms and Conditions of Airflow, which are a part of the accompanying documentation.

The supplier is not liable for damage caused by unprofessional installation and operation that is not in compliance with the operation and maintenance manual and general practices applied during installation and operation of HVAC equipment and control systems.



Call: 01494 525252

Visit: airflow.com



Airflow Developments Limited
Aidelle House, Lancaster Road,
Cressex Business Park,
High Wycombe, Buckinghamshire,
United Kingdom, HP12 3QP

E-mail: info@airflow.com
Telephone: +44 (0) 1494 525252

airflow.com

© Airflow Developments Limited, Airflow Developments Limited reserve the right, in the interests of continuous development, to alter specifications without prior notice. All orders are accepted subject to our conditions of sale which are available on request

